

# Automatic Door Solutions

For Trade Installers

Your direct supply partner  
for automatic doors



## Index

- 04**     **Who we are**  
Introduction to Record Direct
- 05**     **What we do**  
Overview of our service and support
- 06–07**   **Free Training Courses Available**  
Face to face and online
- 08–11**   **Supply Only Aluminium Doors and Frames**  
Swing and sliding doors solutions to the trade
- 12–15**   **Record STA 20**  
Automatic sliding door operator and kits
- 16–19**   **Record TSA 20**  
Automatic telescopic door operator and kits
- 20–23**   **Record STA 20 Retro-Fit**  
Quick fit sliding door retro-fit kit
- 24–27**   **Record DFA 127**  
Heavy duty versatile swing door operator and kits
- 28–31**   **Automatic Bi-Folding Door Package**  
Record FTA 20 and FTA 20 FBO
- 32–33**   **Safety Sensors**  
Some of our most popular sensors
- 34–35**   **Accessories**  
Some of our most popular accessories

# Who we are, what we do ...

Record Direct is the trade supply-only division of Record Group a business within the ASSA ABLOY Group, dedicated to serving the needs of independent automatic door companies looking for high-quality products and the very best service and support.

All our swing and sliding door operators come fully built; ready to install providing time-saving solutions for our customers, whilst our large stock range and five nationwide offices enable us to provide the fastest lead times in our industry.

## Standard Customer Support Includes

- Dedicated field-based account managers
- On-site technical support (advanced planning required)
- Technical telephone support
- Same day dispatch of goods (subject to availability and order processed by 2pm)
- Direct deliveries to customers or drop shipping to a specified location (subject to approval, additional costs may apply)
- Specification advice and support
- Free product literature and marketing support
- Access to technical training (basic, intermediate and advanced) and commercial sales training
- Product Identification
- Access to full range of spares for all standard Record products
- Access to Record's doors and frames systems – manufactured to suit site environments
- Full "Door Automation in a Box" packages

## Distributor Support Includes

- Direct deliveries to the distributors head office address only
- Specification advice and support
- Technical telephone support
- Free product literature
- Product identification
- Access to full range of spares for all standard Record products
- Full "Door Automation in a Box" packages

supply only doors sliding doors  
telescopic doors screen work  
**training & support**  
technical advice spare parts  
**automatic door equipment**  
large stocks available barriers  
**quality & reliable products**  
retro-fit kits **fully built operators** 1 year warranty  
sensors next day delivery UK factory  
**excellent service**  
national distribution folding doors  
swing doors time-saving solutions



## Face to Face Training for all customers

**Record Direct** offers face-to-face training courses on our range of automatic doors for all Direct customers and their technicians. Courses are available at our offices in Hemel Hempstead, Farnborough, Coleshill, Dewsbury and Blantyre and are **FREE OF CHARGE**.

With the capacity to offer up to 20 days of training per month, our experienced Technical Support Managers can satisfy the needs of engineers already experienced in automatic doors and those who are new to the industry.

### The training courses available include:

- » Installation of swing and sliding automatic doors
- » Service and fault finding
- » Folding doors
- » EN16005 explained (the safety standard for powered pedestrian doors)
- » Automatic Door Sensors

All training courses are one full day per product. Training starts at 09.30 and finishes at approximately 16.30.

Each course is designed for a maximum of 4 people in Coleshill and Hamilton and 5 people in Hemel, Farnborough and Dewsbury. All training courses must be pre-arranged. Out of hours, training is available on request.

### Online training courses

We also offer free 2-hour online training courses for office-based customers who work in sales, service, estimating and project management and require an introduction to automatic doors and Record equipment.

These courses have been designed to help staff identify potential sales opportunities and gain useful information to improve customer relations.



**To find out more information/availability for our training courses please scan here**



### BS EN 16 005

All our training courses are in line with BS 16 005. For further details on this standard please scan here.

# Supply Only Aluminium Doors and Frames

Record Direct manufactures a wide range of high quality aluminium swing, sliding and bi-folding automated door solutions to the trade. Our doorsets are prepped and ready for you to install and can be delivered to you, your site or you can arrange collection from one of our hubs.

## Applications

Suitable for shopfronts, commercial offices, public and institutional buildings, healthcare facilities, education projects and also on emergency escape routes.

## Key features & benefits

- » Fine frame automatic sliding door profiles for visual appeal
- » Commercial automatic swing and sliding door profiles for robust, heavy duty environments
- » Allows maximum opening width to be achieved thereby easing traffic flow
- » All systems tested to 1 million cycles
- » Bespoke tailored solution to meet your project requirements
- » Designed to meet the requirements of EN 16005 power operated pedestrian doorsets. Safety in use.

## Specification

### Door Leaves

Fabricated from standard 45mm aluminium square-cut components, mechanically jointed using self-tapping screws, supplied complete with top/bottom door preps, 1 no Adams-Rite high security hook lock, double wool pile to door stiles, mid-rail, flush-pull handles and standard glazing beads. Our frames shall arrive on site with a low-tack protection tape.

### Glazing

All glazing carried out in accordance with BS EN 12600. All glass is dry-glazed using a combination of captive and wedge gaskets manufactured in accordance with BS 3734.

### Finish

Aluminium profiles are normally supplied coated using the powder coat method. Powder coat is available in a wide range of standard colours and surface finishes. Bespoke colours can be provided but may be subject to extended delivery times and additional costs. Aluminium profiles can also be clear anodized in a satin silver finish. Powder coating is to BS6496: 1984. Anodising (natural silver) is to BS3987: 1991

## 1. Automatic Sliding Doors

Record automatic sliding doors and telescopic sliding doors provide all applications for the individual design of your entrance area. No matter if you prefer an elegant fine frame application with a compact operator or a functional and robust commercial frame structure, the Record aluminium door system is the perfect solution for your entrance.



| Door type                | E-STA (one leaf)                             | D-STA (two leaves)           | E-TSA (two leaves)                           | D-TSA (four leaves)                                 |
|--------------------------|--|------------------------------|--|---|
| Opening width            | 800 – 3 000 mm                               | 800 – 3 000 mm               | 800 – 3 000 mm                               | 1 200 – 4 000 mm                                    |
| Clear height of passage  | 3 000 mm                                     | 3 000 mm                     | 3 000 mm                                     | 3 000 mm  |
| Max. door leaf weight    | 1 x 150 kg                                   | 2 x 120 kg                   | 2 x 90 kg                                    | 4 x 80 kg   |
| DUO / RED model          | 1 x 150 kg                                   | 2 x 150 kg                   | 2 x 120 kg                                   | 4 x 90 kg   |
| Reinforced (20-200 / 22) | 1 x 200 / 1 x 250 kg                         | 2 x 150 / 2 x 200 kg         | 2 x 130 / 2 x 170 kg                         | 4 x 90 / 4 x 130 kg                                 |
| Recommended application  | single leaf door automation for tight spaces | for most normal applications | for maximum width of passage in tight spaces | for elegant entrances and generous width of passage |

## Profile options

### 1) Record Commercial Sliding Door System

This automatic door system is a rugged and resilient solution, perfect for your external entrances. The robust 45 mm aluminium frame profiles are ideal for high-traffic entrances where impact damage is a consideration.

### 2) Record Fine Frame Sliding Door Systems

Slim line profiles of 20 mm for 10 mm thick single glazed leaves, or 32 mm thick aluminium profiles for 24 mm thick insulating glass. These fine frame automatic sliding door systems give an aesthetically pleasing, yet highly functional entrance offering the greatest possible transparency. It reduces both the weight and footprint of door leaves and enhances the appeal of any facility without any loss in quality.

## Product options for both profiles

- » Single sliding aluminium doors
- » Double sliding aluminium doors
- » Telescopic sliding aluminium doors

# Supply Only Aluminium Doors and Frames

## 2. Automatic and Manual Swing Doors

Record, swing, sliding, automatic and manual aluminium doors are a traditional solution which is tried and tested and will give long, reliable, virtually maintenance free service.

### Profile options

Fabricated from standard 45mm aluminium square-cut components, mechanically jointed using self-tapping screws, supplied complete with anti-finger trap stile, 1 no Adams-Rite high security hook lock, double wool pile to door stiles, mid-rail (optional), handles and standard glazing beads.

### Included as standard:

- » 1 x Adams-Rite hook lock
- » Double ramped threshold
- » 6.4 mm laminated glass
- » Free-swinging pivots
- » Round anti-finger trap stile
- » 2 x flush bolts (double doors)
- » 25x300 straight pull handles (PPC)

### Product options

- » Single automatic swing aluminium doors
- » Double automatic swing aluminium doors
- » Single swing aluminium doors
- » Std 150mm midrail
- » Double sliding aluminium doors
- » Std 150 mm midrail



Automatic swing door



Manual swing door

## 3. Safety Pocket Doors

Record safety pocket doors offer the perfect safety solution for automatic sliding doors to protect against any entrapment or collision from pedestrian traffic. These have been designed in compliance with BE EN 16 005.

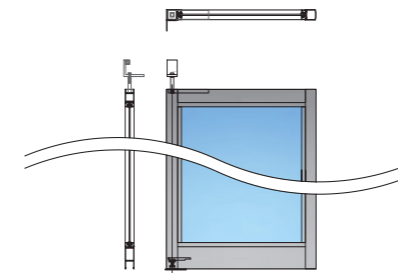

### Profile options

#### 1) Record Commercial Safety Pocket Door System

This safety pocket door system is a rugged and resilient solution, using our robust 45 mm aluminium frame profile are perfect for all entrances.

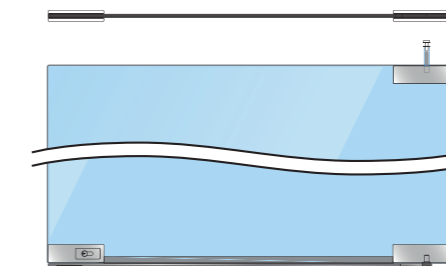

#### 2) Record Frameless Pivoted Pocket Door System

Full height frameless pocket screens constructed from 10 mm toughened safety glass and patch fittings. This pocket door system gives an aesthetically pleasing entrance and provides the greatest possible transparency.

### Product options

- » Fully framed commercial system
  - Protective pocket door
- » Frameless pivoted patch fitted system
  - Protective pocket door
  - Requires Record STA operator

## 4. Aluminium Screenwork

Record aluminium commercial shopfront and screenwork solutions are designed and manufactured to match your specific project requirements.



### Profile option

Record non-thermally insulated aluminium shop-front system. Extruded aluminium is Aluminium Alloy 6063:T6 to BS EN 755 part9: 2001. Manufactured and constructed from standard extruded aluminium profiles 100mm x 45/50mm with glazing to be single-glazed or double-glazing up to 24mm thick. Our frames will arrive on site with a low-tack protection tape.

### Product options

Speak to your Regional Account Manager for available options.



Scan here for more information

# Automatic Sliding Door Operator



The Record STA 20 is a classic, well-proven single and double-leaf automatic sliding door system. With a unique learning ability to automatically adjust, the STA 20 offers outstanding reliability and ongoing performance.

## Applications

Suitable for high traffic areas such as offices, retail stores, supermarkets, hospitals, educational facilities, leisure attractions and public buildings.

## Key benefits

- » Provides barrier-free access for all pedestrians and wheelchair users
- » Aesthetically pleasing appearance to suit all building styles
- » All models can be adapted for security or used on escape routes.
- » Incredibly reliable, resulting in lower service and maintenance costs
- » Exceptionally quiet in operation, ideal for areas where low noise is essential
- » Simplified commissioning for quicker assembly
- » Interactive communication between components to monitor and enhance performance, safety and security
- » User-friendly BDE-D mode switch, with menu-led navigation to program/control doors to suit your needs.



# Automatic Sliding Door Operator and Kits

## Key features

- › Low profile 108mm drive units
- › Modular construction
- › Wide range of models and applications
- › High capacity with efficient and low noise operation
- › Failsafe electric motor brake locking (option) with extended battery backup
- › Continuous self-monitoring system with diagnostics
- › Low noise, long life, replaceable track system
- › Running carriage with hardened nylon wheels
- › Motor and guide pulley with sealed bearings
- › Low momentum toothed belt drive for minimum wear and low acoustic impact.
- › Height adjustable trolleys with anti-rise and long wear wheels
- › Matching profiles for standard and telescopic units

## Specifications

|                        |   |
|------------------------|---|
| Max. opening speed     | 0.7m/s (adjustable)                                       |
| Max. closing speed     | 0.7m/s (mass-dependent adjustable)                        |
| Hold-open time, day:   | 0–30 s (adjustable) adjustable time until the door closes |
| Mains power connection | 230 VAC, 50 Hz  |
| Protection rating      | For use in dry locations only                             |
| Power consumption      | 100W max, 20W idle mode                                   |
| Power output           | < 10mW  |
| Ambient temperature    | –15°C to +50°C  |
| Response time, max.    | < 50 ms   |

## Recommended application limits: Standard sliding door

| Door type            | Single      | Bi-part     |
|----------------------|-------------|-------------|
| Opening width        | 800-3000 mm | 800-3000 mm |
| Clear passage height | 3000 mm     | 3000 mm     |
| STD max. door weight | 1 x 150 kg  | 2 x 120 kg  |
| DUO max. door weight | 1 x 200 kg  | 2 x 150 kg  |

## Product sizes

|                                    |
|------------------------------------|
| Single @ 3000 mm - anodised canopy |
| Double @ 4700 mm - anodised canopy |
| Double @ 6000 mm - anodised canopy |
| Single @ 3000 mm - mill canopy     |
| Double @ 4700 mm - mill canopy     |
| Double @ 6000 mm - mill canopy     |
| Cut & build charge                 |
| Electric lock - VRR                |

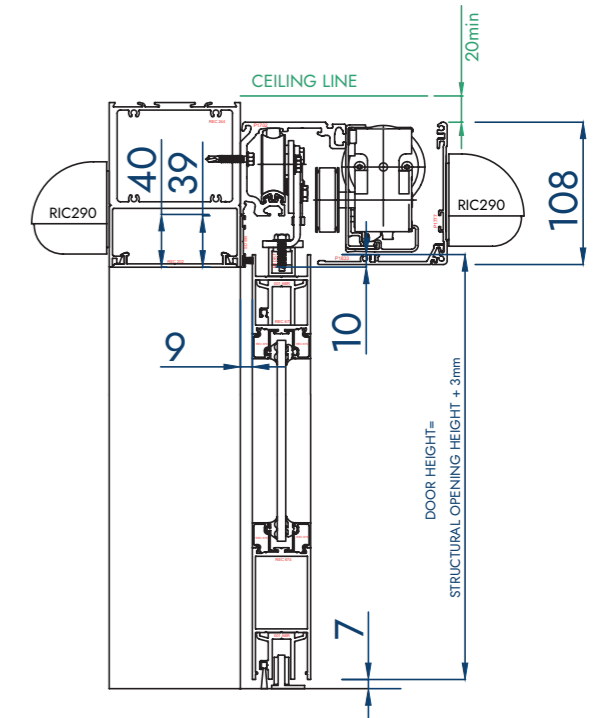

## Sensors & Signage Package includes:

### Single @ 3000 mm

3000 mm operator, BDE-D, 2 x RIC290, AIS290, signage: 1 x automatic door (double sided) and 1 x keep clear.

### Double 4700 mm & Double 6000 mm

4700 mm or 6000 mm operator, BDE-D, 2 x RIC 290, 2 x AIS290, signage: 2 x automatic door (double sided) and 2 x keep clear.

## Full Equipment Package includes:

### Single 3000 mm

3000mm operator, BDE-D, 2 x RIC290, AIS290, signage: 1 x automatic door (double sided) and 1 x keep clear, adjustable floor guide, length of channel to suit, morning entry key switch and stainless steel back box to suit key switch.

### Double 4700 mm & Double 6000 mm

4700mm or 6000mm operator, BDE-D, 2x RIC 290, 2 x AIS290, signage: 4 x automatic door (double sided) and 2 x keep clear, 2 x adjustable floor guide, 2 lengths of channel to suit, morning entry key switch and stainless steel back box to suit key switch.

All operators are fully built with BDE, belt, carriage assemblies, hanger brackets and top rail adaptor.



Scan here for more product information



TSA20

## Automatic Telescopic Door Operator



Record TSA 20 telescopic sliding doors take up about 30% less space thanks to their slimmer leaves to create a wider clear opening compared to standard sliding doors.

### Applications

Suitable for narrow passageways and entrances in offices, retail stores, supermarkets, hospitals, educational facilities, leisure attractions and public buildings

### Key benefits

- » Robust construction and precise microprocessor, utilises the same track and components of the Record System 20.
- » Two and four-leaf telescopic sliding doors can cover particularly large openings widths of up to 4,000 mm.
- » Heavy-duty automatic door provides exceptional power, safety and reliability
- » Versatile operator integrates effortlessly with access control, fire alarms and control systems.
- » Exceptionally quiet in operation, ideal for areas where low noise is essential
- » Aesthetically pleasing appearance to suit all building styles
- » Incredibly reliable, resulting in lower service and maintenance costs
- » Simplified commissioning for quicker assembly
- » Malfunction potential is greatly reduced by the drive monitoring ability
- » Self-learning processor with active automatic adjustment for ongoing quality performance.



# Automatic Telescopic Door Operator and Kits

## Key features

- › Low profile 108mm drive units
- › Modular construction enables a wide range of models and applications
- › High capacity with efficient and low noise operation
- › Failsafe electric motor brake locking (option) with extended battery backup
- › Continuous self-monitoring system with diagnostics
- › Low noise, long life, replaceable track system
- › Running carriage with hardened nylon wheels which have sealed bearings and compensation for structural tolerance
- › Motor and guide pulley with sealed bearings
- › Low momentum toothed belt drive for minimum wear and low acoustic impact.
- › Height adjustable trolleys with anti-rise and long wear wheels
- › Matching profiles for standard and telescopic units

## Specifications

|                        |  |
|------------------------|--|
| Max. opening speed     | 0.7m/s (adjustable)  |
| Max. closing speed     | 0.7m/s (mass-dependent adjustable)                           |
| Hold-open time, day:   | 0–30 s (adjustable)<br>adjustable time until the door closes |
| Mains power connection | 230 VAC, 50 Hz   |
| Protection rating      | For use in dry locations only                                |
| Power consumption      | 100W max, 20W idle mode                                      |
| Power output           | < 10mW   |
| Ambient temperature    | –15°C to +50°C   |

## Recommended application limits: Telescopic sliding door

| Door type            | Single (two leaves) | Bi-part (four leaves) |
|----------------------|---------------------|-----------------------|
| Opening width        | 800-3000 mm         | 800-3000 mm           |
| Clear passage height | 3000 mm             | 3000 mm               |
| STD max. door weight | 2x 90 kg            | 4 x 80 kg             |
| DUO max. door weight | 2 x 120 kg          | 4 x 90 kg             |

## Product sizes

|                                    |
|------------------------------------|
| Single @ 3000 mm - anodised canopy |
| Double @ 4700 mm - anodised canopy |
| Double @ 6000 mm - anodised canopy |
| Single @ 3000 mm - mill canopy     |
| Double @ 4700 mm - mill canopy     |
| Double @ 6000 mm - mill canopy     |
| Cut & build charge                 |
| Electric lock - VRR                |

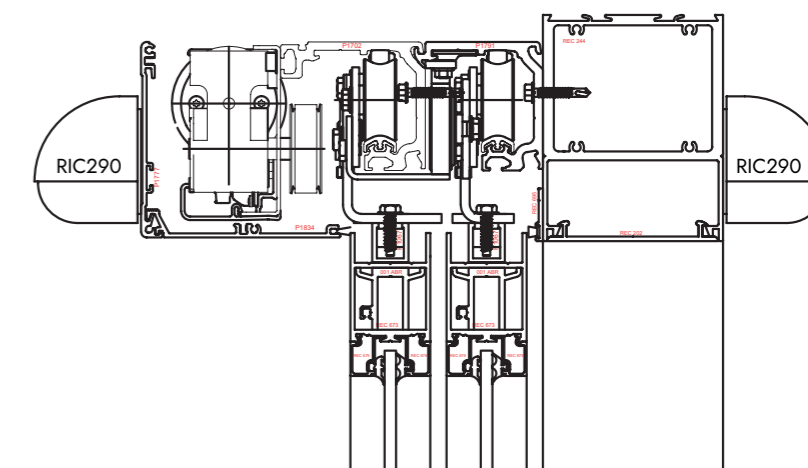

## Sensors & Signage Package includes:

**Single @ 3000 mm**  
3000mm operator, BDE-D, 2 x RIC290, AIS290, signage:  
1 x automatic door (double sided) and 2 x keep clear

**Double 4700 mm & Double 6000 mm**  
4700mm or 6000mm operator, BDE-D, 2 x RIC290, 2 x AIS290,  
signage: 2 x automatic door (double sided) and 4 x keep clear.

## Full Equipment Package includes:

**Single 3000 mm**  
3000 mm operator, 2 x RIC290, AIS290, signage: 1 x automatic door (double sided) and 2 x keep clear, adjustable floor guide, telescopic floor guide, 2 lengths of channel to suit, morning entry key switch and stainless steel back box to suit.

**Double 4700 mm & Double 6000 mm**  
4700mm or 6000 mm operator, 2 x RIC290, 2 x AIS290, signage:  
2 x automatic door (double sided) and 4 x keep clear, adjustable floor guide, 2 x telescopic floor guide, 4 lengths of channel to suit, morning entry key switch and stainless steel back box to suit.

All operators are fully built with BDE, belt, carriage assemblies, hanger brackets and top rail adaptor.



Scan here for more product information

## Quick Fit Sliding Door Retro-Fit Kit

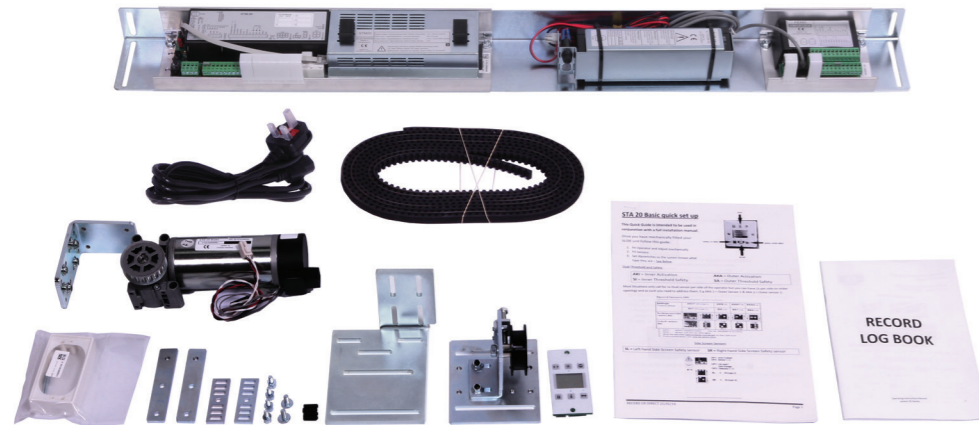

The Record STA 20 is the perfect solution to renew outdated or faulty existing sliding door equipment. Why replace one costly component when for a more economical solution you can replace all of the major components whilst reusing the housing and wheels with a STA 20 retrofit kit. Complete with a 12 month warranty, this retrofit kit will keep your customers' doors going for longer.

### Applications

Especially suitable for offices, retail outlets, care homes, hospital wards, educational facilities, libraries, restaurants, and hotels.

### Key benefits

- » Upgrade obsolete or un-economical sliding operators FAST
- » Order kits by manufacturer and model to ensure you get the right kit for the right operator, saving valuable time and money.
- » Bespoke brackets to match the existing operator for easy fitting.
- » No need to drill and tap with our product specific bracketry.
- » Most installations are achieved in under 3 hours including wiring and set-up.
- » Only one engineer required for installation
- » Everything comes complete in bespoke packaging for its safety and your peace of mind during transport.



## Quick Fit Sliding Door Retro-Fit Kit



### Key features

- » All equipment mounted on a single easy to fit module
- » Motor conversion bracket allows fitting an STA 20 motor in place of a standard "Dunkermotor".
- » Control, fem-0 board, battery, motor, belt and BDE-D – all in one box.
- » Operator specific kits – including a universal kit that will fit 90% of all sliding door operators.
- » Instructions included
- » UK mains lead

### Specifications

|                        |  |
|------------------------|--|
| Max. opening speed     | 0.7m/s (adjustable)  |
| Max. closing speed     | 0.7m/s (mass-dependent adjustable)                           |
| Hold-open time, day:   | 0–30 s (adjustable)<br>adjustable time until the door closes |
| Mains power connection | 230 VAC, 50 Hz   |
| Protection rating      | For use in dry locations only                                |
| Power consumption      | 100W max, 20W idle mode                                      |
| Ambient temperature    | –15°C to +50°C   |
| Frame size             | STD: 160mmH x 166mmD<br>LP: 110mmH x 166mmD                  |

### Recommended application limits: Standard sliding door

| Door type            | Single (two leaves) | Bi-part (four leaves) |
|----------------------|---------------------|-----------------------|
| Opening width        | 800-3000 mm         | 800-3000 mm           |
| Clear passage height | 3000 mm             | 3000 mm               |
| STD max. door weight | 1x 150 kg           | 2 x 120 kg            |
| DUO max. door weight | 1 x 200 kg          | 2 x 150 kg            |

Please note - most retrofit kits will be a maximum of 120kgs per door leaf, unless duo which is 150kgs per door

### Our STA 20 retro-fit kits are compatible with the following operators

|                       |                        |
|-----------------------|------------------------|
| Besam EMD             | Jmd SILENT SLIDE       |
| Besam EMC             | Horton 2003 / 2001     |
| Besam EML             | Portalp Diva           |
| Besam EMDE            | record STA 13          |
| Besam EMJ             | record STA 14          |
| Besam EMD v9          | record STA 16          |
| Besam UNISLIDE / EMSL | record STA 17          |
| Besam SL500           | Stanley DURAGLIDE 2000 |
| Ditec Bis O           | Stanley DURAGLIDE J    |
| Ditec BIS V           | Tormax TEP             |
| Dom ASTROSLIDE 2000   | Tormax TMP             |
| Dorma ES60            | Tormax TXP             |
| Dorma ES70            | Tormax TLP             |
| Dorma ES90            | Tormax 2201 Windrive   |
| Dorma ES200           | Universal Kit          |
| Geze TSA 350 N        | Waldoor UWS 2400       |
| Gilgen SLM (old)      |                        |

Further retro-fit kits are always being developed. Please contact your Regional Account Manger if your operator is not listed

### Sensors & Signage Package includes:

#### Single

Retro-Fit Kit, 2 x RIC290, AIS290, signage: 1 x automatic door (double sided) and 1 x keep clear.

#### Double

Retro-Fit Kit, 2 x RIC290, 2 x AIS290, signage: 2 x automatic door (double sided) and 2 x keep clear.

### Full Equipment Package includes:

#### Single 3000 mm

Retro-Fit Kit, 2 x RIC290, AIS290, signage: 2 x automatic door (double sided) and 1 x keep clear, adjustable floor guide, length of channel to suit, morning entry key switch and stainless steel back box to suit.

#### Double

Retro-Fit Kit, 2 x RIC290, 2 x AIS290, signage: 2 x automatic door (double sided) and 2 x keep clear, 2 x adjustable floor guide, 2 lengths of channel to suit, morning entry key switch and stainless steel back box to suit.

We have a range of retro-fit kits designed to upgrade obsolete or un-economical sliding operators FAST.



Scan here for more product information

DFA127

## Heavy Duty Versatile Swing Door Operator

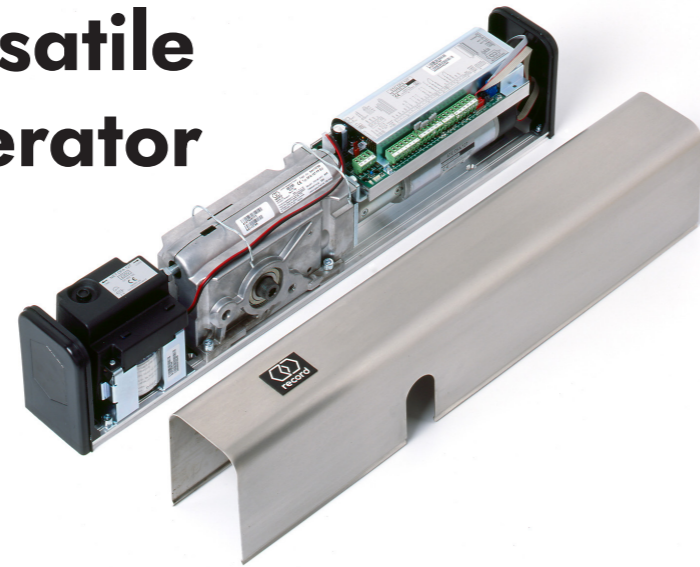

The Record DFA 127 is a universal drive system for the automation of swing doors and the market leading operator in the UK, with over 10,000 units sold each year. Its broad range of applications makes it suitable for widely differing requirements from Full Power, Low Energy for slow-moving traffic, people, inverse and fire.

### Applications

Especially suitable for offices, corridors, care homes, hospital wards, educational facilities, libraries, restaurants and hotels.

- » Market leading operator in the UK
- » Tested to 1 million cycles - 500K more than the required testing
- » Reliable Swiss quality - fit and forget
- » Popular for a reason - robust, versatile and simple to install
- » UK fire certification

### Key benefits

- » Automates existing and new swing doors quickly and economically.
- » Adjustable spring force enables the DFA to be adjusted on the spot to operate a range of door sizes with a spring closing force from EN4 to EN6.
- » Extremely versatile, can be set up as either FULL POWER for heavier doors or LOW ENERGY for slow-moving traffic.
- » Compact design, aesthetically appealing to suit all building styles
- » Silent in operation, making it suitable for quieter areas where low noise is essential.
- » Robust and reliable, easier to maintain and service.
- » Has been approved for use as a hold-open system for fire protection barriers
- » Can be used with various fire-protection profile systems such as Jansen, Forster, Heroal and Schuco.



### Product range

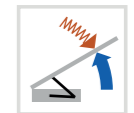

FULL POWER



LOW ENERGY



INVERSE



FIRE

DFA127

# Heavy Duty Versatile Swing Door Operator

## Key features

- » Extensive functionality without additional modules
- » Refined technology
- » Programmable microprocessor
- » Motion sensor activated
- » Ingenious mechanics, ensure optimum power deployment is achieved in the entire door swing area.
- » Complies with the latest standards for safety requirements.

## Specifications

|   |  |
|---|--|
| Door closer size  | EN4-EN6 for standard arm and slide arm.                      |
| Opening time/closingtime  | 3-20s/5 - 20s  |
| Opening angle   | 70-115O (INVERSE up to 95O)s                                 |
| Electrical power supply   | 230 VAC, 50/60Hz   |
| Rated power   | 67W  |
| Consumption in standby mode   | 13W  |
| Dimensions (H x W x L)  | 85 x 124 x 600mm   |
| Max. recess   | Push 330mm<br>Pull 200mm                                     |
| Operating modes with internal BDI operating switch  | Automatic operation<br>Continuously open<br>Manual operation |
| Operating modes BDE-D control panel with display (optional) In addition to the standard modes | Locked<br>One-way traffic<br>Operation lock                  |

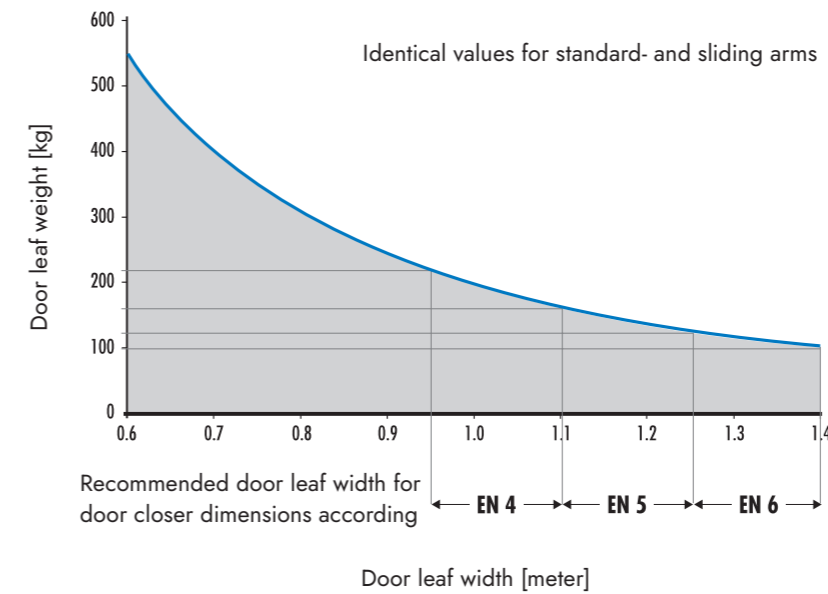

## Product

- » Push unit (With arm)
- » Pull Unit (With arm and packer)
- » RC Swing 700mm

### DFA 127 EN16005 Standard Package:

#### DFA single sensor kit:

1 x DFA 127 operator, 2 x RC swing door leaf sensors including door loops, activation sensors, (1 x uni and 1 x bi-directional), signage: 1 x automatic door (double sided), 1 x keep clear.

#### DFA double sensor kit:

2 x DFA 127 operators, 4 x RC swing door leaf sensors including door loops, activation sensors, (2 x uni and 1 x bi-directional), 1 x can isolator, signage: 2 x automatic door (double sided) and 2 x keep clear.

### DFA 127 EN16005 Complete Package:

#### DFA single full kit:

1 x DFA 127, 2 x RC swing door leaf sensors including door loops, activation sensors (1 x uni and 1 x bi-directional), signage: 1 x automatic door (double sided), 1 x keep clear, morning entry key switch and stainless steel back box to suit keyswitch, 3 position key switch, BDI-M.

#### DFA double full kit:

2 x DFA 127 operators, 4 x RC swing door leaf sensors including door loops, activation sensors, (2 x uni and 1 x bi-directional), 1 x can isolator, signage: 2 x automatic door (double sided), and 2 x keep clear, morning entry key switch and stainless steel back box to suit keyswitch, 3 position key switch, BDI-M.

Automate new and existing manual swing doors quickly and economically



Scan here for more product information

## Automatic Bi-Folding Door Package

Record folding doors and their variants are recognised as design leaders internationally. The standard FTA 20 folding door is excellent for limited spaces, where the use of sliding doors is prohibited, as it maximises your clear opening width. The FTA 20 FBO shares all the same features but can also be used on escape routes, thanks to its optional break-out function.

### Applications

Suitable for narrow passageways and entrances in restaurants, kitchens, airports, offices, hospitals, care homes, educational establishments and leisure facilities. Especially suitable as entrance doors in windy conditions.

### Key benefits

#### Record FTA 20

- › Ideal for entrances with limited space, the width of the passage can almost be fully retained.
- › These space-saving doors fold inwards negating the need for added room around an entrance.
- › Can be easily retrofitted to save valuable time and money on installation.
- › Excellent for windy environments, as doors remain easy to open and close.
- › Designed to work well when fitted into corridors or to section off areas such as the kitchen to the dining room in a restaurant.
- › Reliable and robust, easier to maintain and service
- › Aesthetically pleasing and compliments all architectural designs.

#### Record FTA 20 FBO

Benefits from all of the above and ...

- › Provides an escape or exit route in narrower or restricted spaces in an emergency.
- › Simply and easy to open — access to escape routes is provided by light pressure on the door panels.
- › Door panels open in the direction of escape, enabling users to exit as quickly as possible.

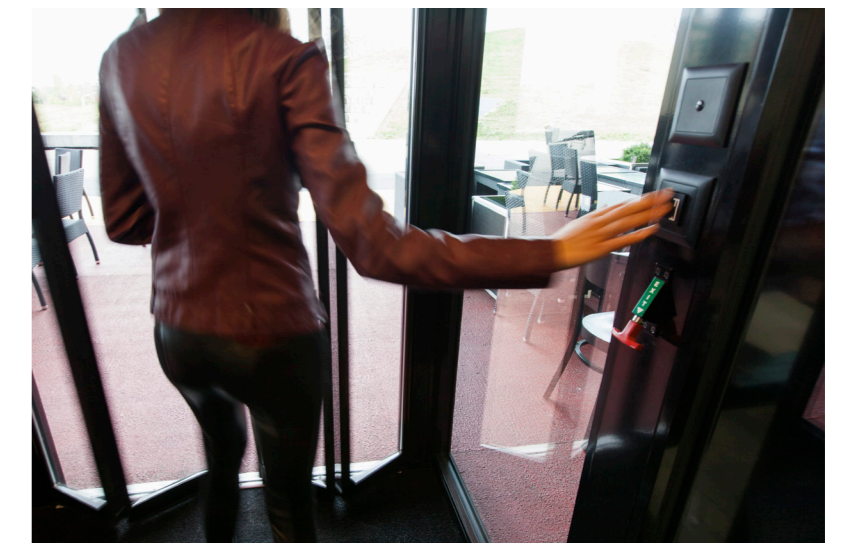

# Automatic Bi-Folding Door Package

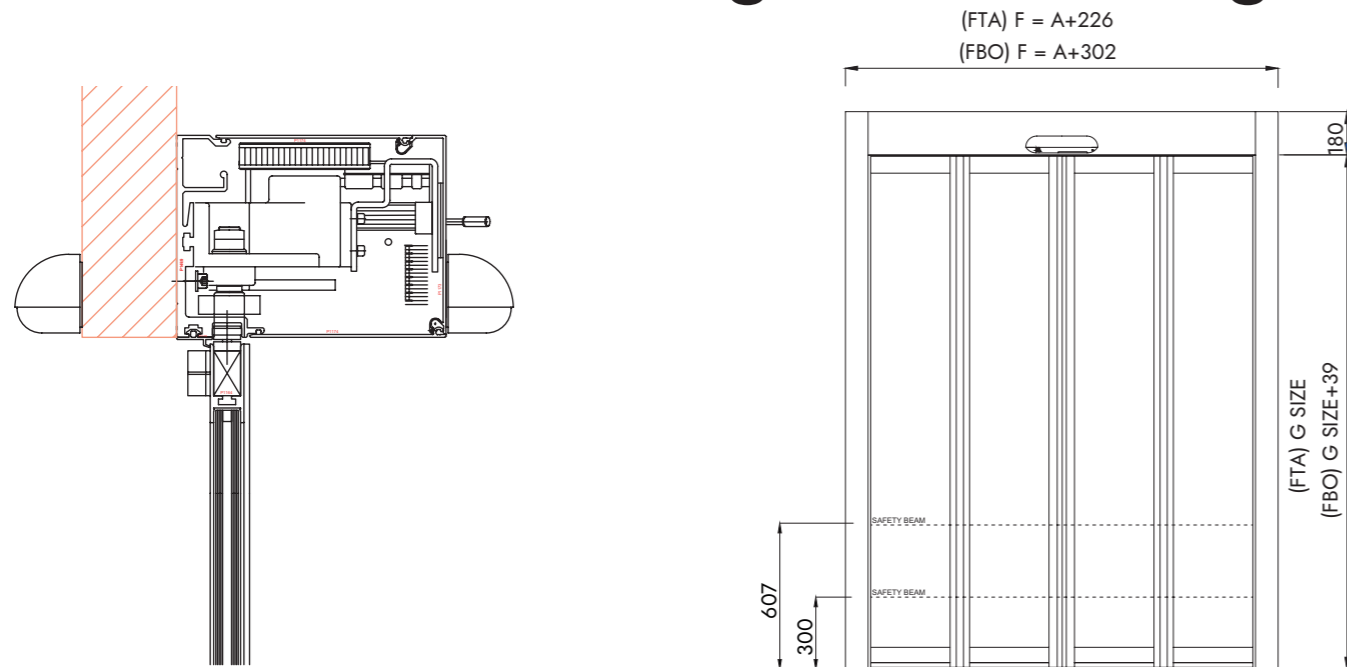

## Key features

- › Can be used as one-sided or two-sided units, depending on the total width available
- › Available in various dimensions
- › Doors can be retrofitted into the wall
- › For FTA 20 FBO – doors open outwards
- › Hinged doors
- › Controllable parameters such as speed and opening time
- › Easily programmable

## Specifications

|                             |                           |
|-----------------------------|---------------------------|
| Door operating speed:       | up to 0.7m/s (adjustable) |
| Operating housing dimension | D x H: 240 x 180 mm       |
| Power supply:               | 230 V AC / 50 / 60 Hz     |
| Power consumption:          | 100 W max, 20 W idle mode |
| Ambient temperature:        | - 15 °C to + 50 °C        |

## Recommended application limits: Folding sliding door

|                          |                               |
|--------------------------|-------------------------------|
| Door type:               | Single Folding Double Folding |
| Opening width:           | D x H: 240 x 180 mm           |
| Clear passage height:    | 230 V AC / 50 / 60 Hz         |
| Max. door weight:        | 100 W max, 20 W idle mode     |
| Recommended application: | - 15 °C to + 50 °C            |

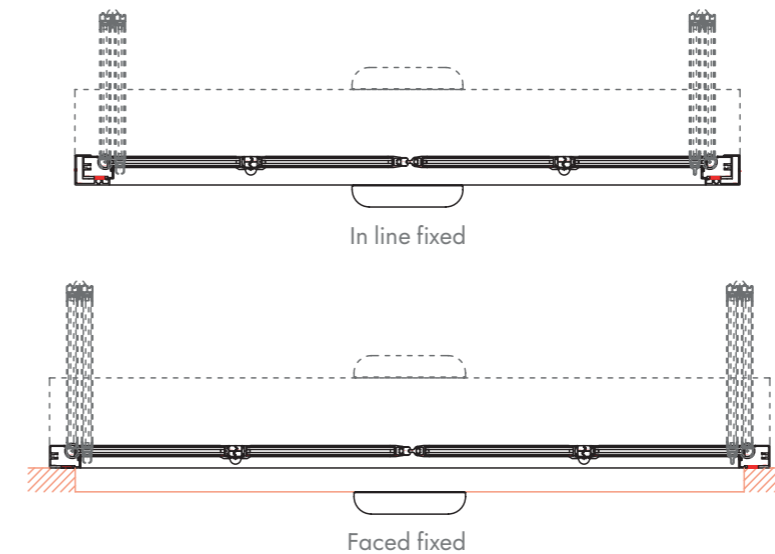

## Operators

- Single Bifold - In-line
- Single Bifold - Faced Fixed
- Double Bifold - In-line
- Double Bifold - Faced Fixed
- Electric Lock

## Sensors & Signage Package includes:

### Single - inline fixed - FTA-SINGLE-T KIT:

Doors and operator PPC, 1 x BDE-D, 2 x RIC 290, 1 x photocell, 1 x Fem 0, 1 x automatic door (double sided) signs & 1 x keep clear sign.

### Single - faced fixed - FTA-SINGLE-S KIT:

Doors and operator PPC, 1 x BDE-D, 2 x RIC 290, 1 x photocell, 1 x Fem 0, 1 x automatic door (double sided) signs & 1 x keep clear sign.

### Double - inline fixed - FTA-DOUBLE-T KIT:

Doors and operator PPC, 1 x BDE-D, 2 x RIC 290, 1 x photocell, 1 x Fem 0, 2 x automatic door signs & 2 x keep clear signs.

### Double - faced fixed - FTA-DOUBLE-S KIT:

Doors and operator PPC, 1 x BDE-D, 2 x RIC 290, 1 x photocell, 1 x Fem 0, 2 x automatic door signs & 2 x keep clear signs.

Excellent for limited spaces where the use of sliding doors is prohibited.



Scan here for more product information



## Safety Sensors

Our sensors are vitally important for ensuring public safety and the intelligent operation of automatic doors. They are designed to detect moving or stationary people in the opening paths and standing areas around doors and stay active when the doors are in motion.

Variable sensitivity adjustments allow sensors to be adjusted to be responsive for every application, including extreme weather conditions.

### Record RC Swing On Door Safety Sensor

The Record RC Swing safety sensor for swing doors is directly mounted on one or both sides of the swing door leaves and functions as a ride sensor. It incorporates all the monitoring requirements of EN 160005.



Suitable for the Record DFA 127 swing operator.

#### Key benefits

- » Active infrared light curtain prevents collision of the door leaf with people or objects
- » Slim design - can be easily positioned on the door leaf, to suit aesthetics of the building.
- » Effortless CAN bus technology for quick and easy installation
- » Multiple active infrared available for wide door leaves to cover the entire opening
- » Width of sensor housing can be individually adapted to suit the aesthetics of a building.
- » Sensors can be set up and adjusted within minutes in the engineer's mode



Scan here for more product information

### Record RIC 290 - Combined Sensor with Microwave and Active Infrared Technology

The Record RIC 290 sensor uses microwave and active infrared technology. Equipped with a combination of motion and presence detectors, it provides an outstanding level of safety with 100% detection of people and obstructions.



Suitable for the Record STA20 and STA 21 sliding doors operators.

#### Key Benefits

- » Can bus plug and play technology provides ease of installation and outstanding safety.
- » Interaction with user or service personnel on an advanced level - resulting in lower service and maintenance costs,
- » Wiring is simple and extremely reliable resulting in stable connectivity between sensors.
- » Time saving, quick and simple commissioning
- » Light curtain prevents collisions with the door leaves.

### Record AIS 290 - Active Infrared Presence Detection Sensor

The Record AIS 290 is an active infrared presence detection sensor with a narrow light curtain, making it ideal for secondary closing edge protection, due to its small field of detection.



Suitable for the Record STA20 and STA 21 sliding doors operators.

#### Key benefits

- » Provides secondary protection to main entrances
- » Extremely reliable, offering an exceptional level of safety
- » Simple to install with CAN bus plug and play technology
- » Easy system integration and self-learning capability
- » Time-saving quick and simple commissioning

## Accessories

At Record Direct we have a wide range of accessories to suit our swing and sliding door operators. These are our most popular ones.



### Record BDE-D Electronic Control Unit

The Record BDE-D is a convenient and user-friendly remote control unit for the intuitive control and programming of doors with Record operators. The LCD display provides data and information regarding the door status by means of symbols and plain text messages.

A slim-line BDE is also available for surface mounted finishes.

Suitable for the Record STA 20 and DFA 127 operators.



### Record BLS 60 Touchless Switch

The Record BLS 60 Switch is hygienic to use, as it automatically opens the door on the approach to the switch, eliminating any contact via hands.

It can be surface or flush mounted, quickly and easily and has an adjustable detection range from 15 to 80 cm.

Suitable for the Record DFA 127 operator.

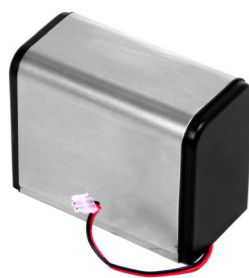

### Record Battery Back Up

The Record Battery Back Up is both powerful and compact. It is ideal for single door openings to provide uninterrupted operation in the event of a power failure.

The battery pack can be attached to the swing door operator or elegantly integrated into the extended operator variant in the kit version.

Suitable for the Record DFA 127 operator



### Record VRR 20 Motorised Locking System

The Record VRR 20 built in motorised locking can be used on single, bi-parting or telescopic doors to offer protection against burglars and opportunist thieves.

Motor-driven in both directions, the VRR is quick and easy to install and is ideal for quieter areas, as they is no noise when the lock is triggered.

Suitable for the Record STA 20 , TSA 20 and FTA 20 operators



### Record EPC 903 Easy Programmer

The Record EPC 903 Easy Programmer is designed specifically for engineers. Lightweight and durable, it enables users the same functionality as a Record BDE-D but without the robustness if a purpose built- handheld programmer.

It is excellent in large installations where multiple operators are set up, as it can be simply plugged into each operator for a quick, easy set-up and programming.

Suitable for the Record STA 20, TSA 20, FTA 20 and DFA 127 operators.



Scan here for more product information



**Contact our  
sales team**

**Record Direct**

Unit 1, Maxted Park  
Maxted Road,  
Hemel Hempstead Industrial Estate  
Hemel Hempstead  
HP2 7EP  
T + 44 (0) 845 643 0013  
E [sales@recordukdirect.co.uk](mailto:sales@recordukdirect.co.uk)

Headquartered in Switzerland, the Record group sells its products and services across the globe and is directly present with subsidiaries in many countries.

Part of ASSA ABLOY